

DIRECTORY:

FITTING POSITIONS SHOWN ARE STANDARD. PLEASE INDICATE WITH DIMENSIONS IF REQUIRED IN A DIFFERENT LOCATION.  
TANK SHOWN IS SUITABLE FOR VDO STYLE SENDER (WITH PICKUP / RETURN PIPES IN SENDER UNIT).

ISSUE	DETAILS	DATE
A	TO BE APPROVED FOR MANUFACTURE	

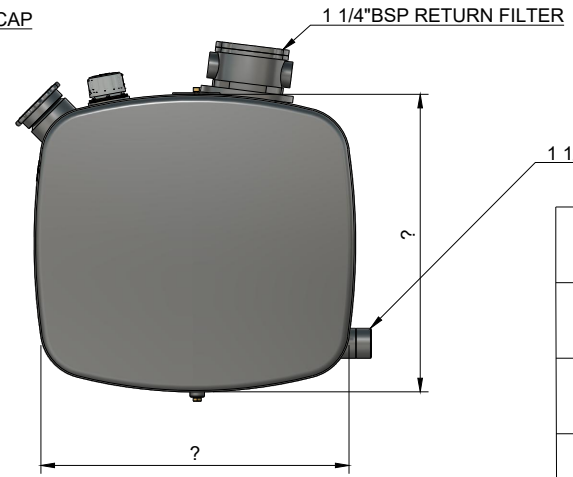
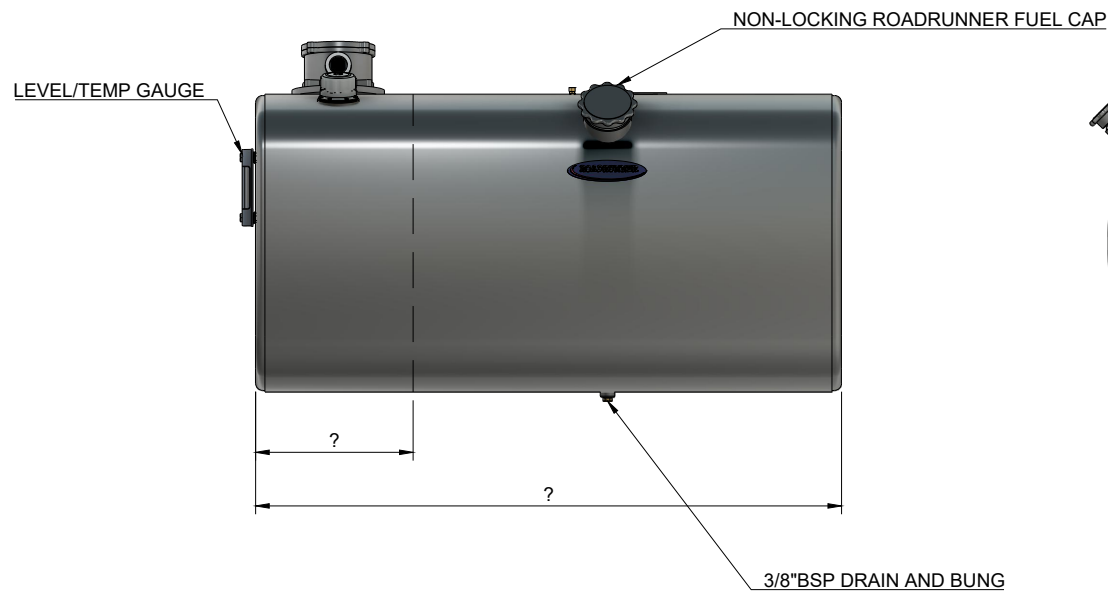
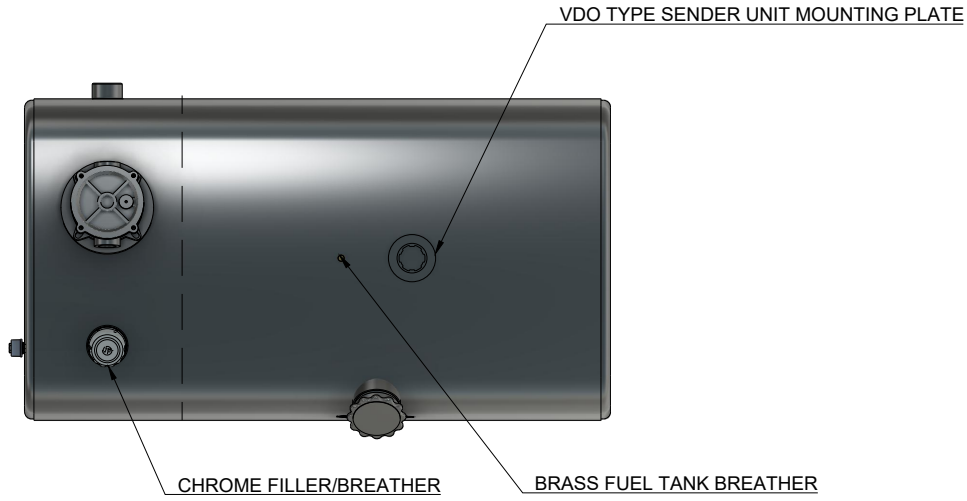

TANK ORIENTATION	
630H x 680D	
680H x 630D	
650H x 700D	
700H x 650D	

THIS DRAWING AND/OR ELECTRONIC MEDIA CONTAINING THIS DRAWING REMAIN THE PROPERTY OF ROADRUNNER MANUFACTURING LTD. IT MAY NOT BE COPIED OR USED IN ANY UNORTHERISED MANNER

**ROADRUNNER**  
ROADRUNNER MANUFACTURING (NZ) LIMITED



CLIENT:		SHEET: 1/1	
TITLE: Oval Sq Combo Tank Specs - VDO Sender	DATE:	SCALE: 1:16	ISSUE:
DRAWN BY: Steve Tunncliffe	PRODUCT CODE:	JOB NUMBER	